

510ml / 16oz (90mm) Black Aqueous Single Wall BioCup BC-16B

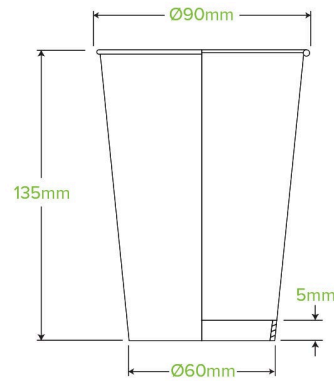

16oz Aqueous Single Wall BioCups are manufactured using a unique water-based dispersion coating certified home compostable to Australian standards (AS5810). These cups are food safe, odorless, and can be disposed of right in your backyard compost bin!

Carton quantity: 1000	Sleeves per carton: 20	Units per sleeve: 50
Carton Size LxWxH (cm): 46x37x63.5	Carton gross weight (kg): 15.000000	Raw Material: Paper - FSC™ Mix certified paper
Lining/coating: Aqueous	Window Material: None	Inks: Food Contact Safe Inks
Brim fill capacity (ml): 518	Dimensions top LxW (mm): 90x90	Dimensions base LxW (mm): 59x59
Product Depth: 136	Product weight (g): 13.5	Thickness: 300gsm+8g aqueous
Use: Hot and cold	Manufactured: China	Customise: Print
MOQ custom: 50000	Mould fees: Yes - see custom packaging	Environmental production certified: TBC
Quality product certified: TBC	Factory food safety certified: BRC	Home compostable: Certified to AS5810 Australian standards, Certified to NF T51-800 European standards
Industrially compostable: Certified to AS4736 Australian Standards, Certified to EN13432 European Standard	Recyclable: No	